

53 Foot Refrigerated Trailer Multi-Temp

Cooling Concepts Trailer Leasing provides only the highest-quality equipment on the market today. All units come equipped with satellite tracking and breakdown assistance is available 24-hours a day.

(800) 225-7623

www.Cooling-Concepts.com

The future of the refrigerated trailer leasing industry is here.

The Cooling Concept's 53-foot refrigerated trailer Multi-Temp is designed to haul products that require various temperatures and is the largest trailer we have. It can be divided up into three different zones, allowing customers to haul various products. The first zone is frozen products. The second zone is for products that need to be kept fresh, and the third zone is for dry products. These separate zones temperatures can all be changed as needed, and this trailer can be used both as a single temp, and dual temperature. It is fully customizable for our customers' needs.

Cooling Concepts Standard:

We at Cooling Concepts are here to help the client and change the standard in refrigerated trailer leasing. We do that by offering our client these features for no extra cost.

Aero Solutions

Provides a 5.5% improvement in fuel mileage

Solar Panels

Extends the battery life to reduce downtime

GPS & Temperature Reporting

Remotely monitor temperature, location, and driver behavior

Air ride Suspension

Extremely Smooth Ride to protect Cargo

PSI tire Inflation

Reduce Road Service calls and improve economy

Low rolling Resistance tires

Reduces harmful emissions and Fuel usage

Hybrid refrigeration units.

Ability to operate on both diesel and electric

Fuel Efficiency

Our Smartway® trailers exceed California Air Resource Board (CARB) regulations, saving our fleet partners fuel and money while protecting the environment.

CCL Cloud

Featuring on-demand accounting, storing and tracking of important documentation, the CCL Cloud portal saves time and money and is a value-added standard feature on all Cooling Concepts refrigerated trailer leases.

Cool Connect Satellite Tracking

Satellite tracking allows you to pinpoint truck locations, protect your assets, and determine exactly when to expect delivery. In short, it takes the guesswork out of refrigeration transportation.

Maintenance And Roadside Assistance

In the case of needing roadside assistance, Cooling Concepts is on-call 24/7. Additionally, our preventative maintenance package is available on trailers and refrigeration units, reduces breakdowns and costs.

Trailer Options

Along with the Cooling Concept Standard, there is a list options to help further customize our trailers to our client's specific needs. These options are:

- Moveable Bulkheads
- Etrack
- Interior lighting
- Walk ramps
- Side mount Ramps
- Lift Gates
- Center Divide
- Pop-up air chutes (center)
- Side chutes
- Weigh Scales
- Side Skirts
- Trailer Undertray System
- Puncture Guard tires

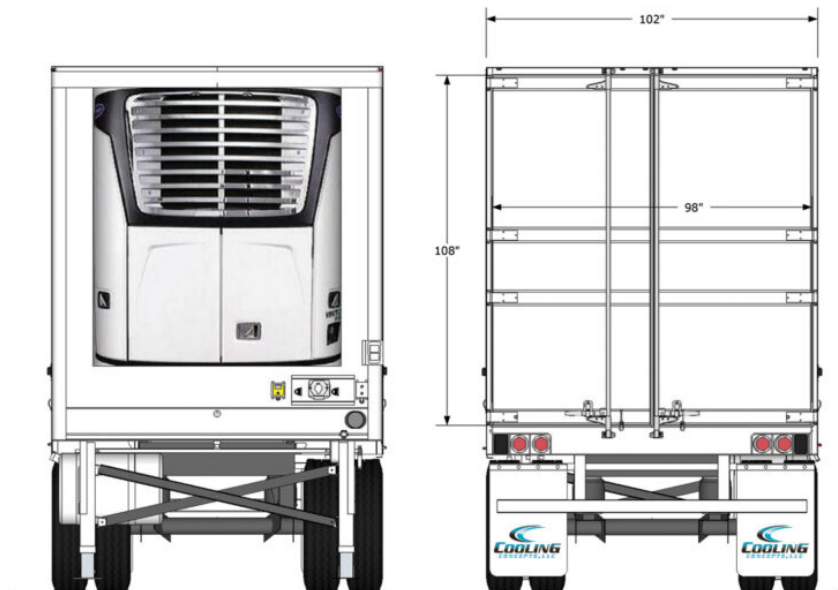

Trailer Dimensions & Spec Sheet

See how the Cooling Concepts 53 Foot Refrigerated Trailer fits in with your fleet needs.

53 FOOT REFRIGERATED TRAILER MEASUREMENTS & SPECIFICATIONS

Overall Length	53'
Overall Width	102"
Overall Height	13'6"
Coupler Height	47"
Kingpin Setting	36"
Dock Height	51-1/2"
Inside Width	97-1/2" at liner
Inside Height	103-1/2"
Door Opening	94" height x 92" width
Cubic Capacity	3,600 cubic feet
Weight	16,200 lbs. +/-3%
Suspension	Full slide range, variable-position tandem axles with Air-Ride suspension. Airbags equipped with self-regulating height control valve and manual dump valve
Axles	5/8" axle wall, 25,000 lb. capacity with synthetic wheel-end lubricant
Tires	295/75R 22.5 premium radial tires
Refrigeration Unit	THERMO KING SPECTRUM or CARRIER GENESIS
Full Tank	50 gallon aluminum fuel tank

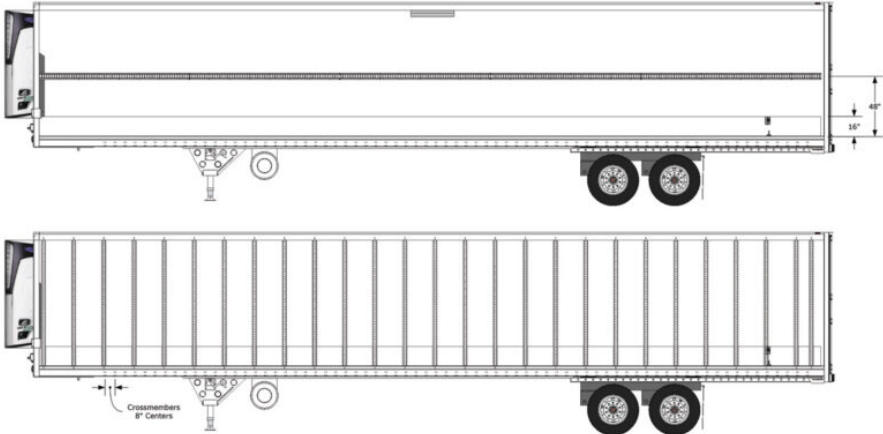

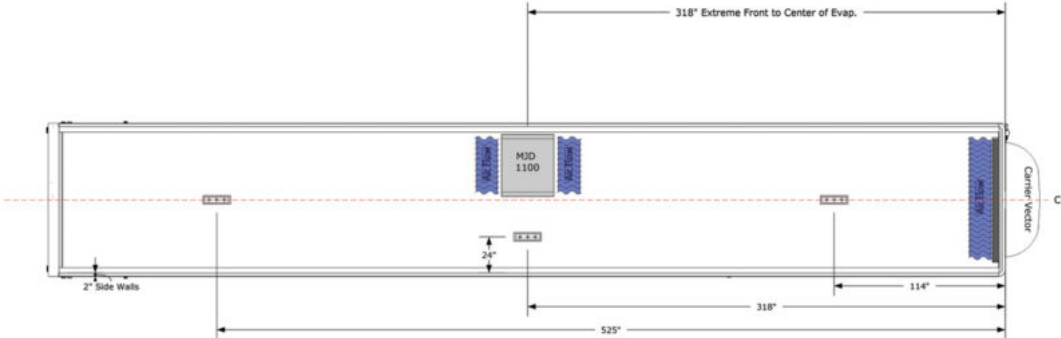

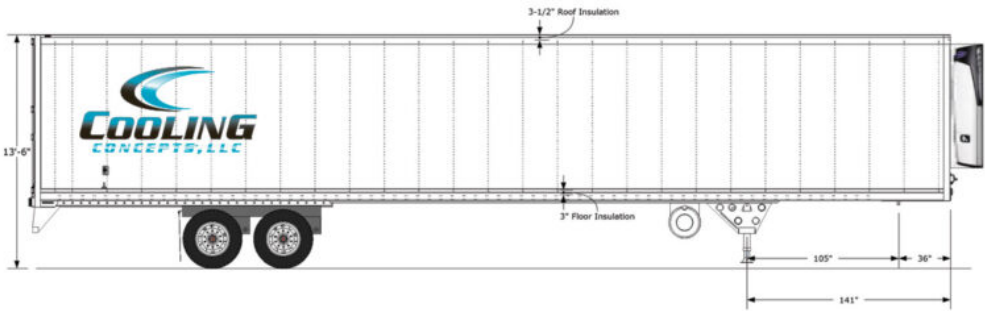
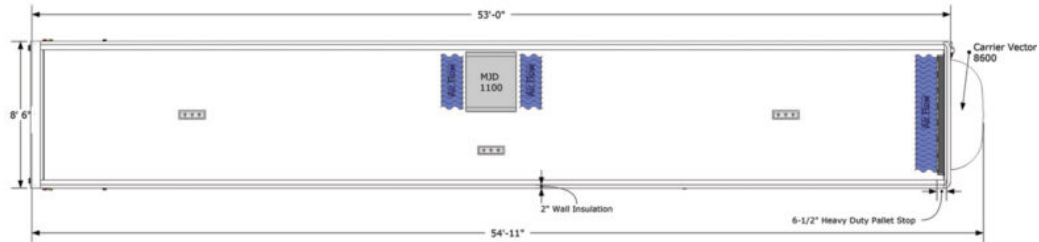

CONTACT US

If you need further assistance or have any question be sure to contact us at one of our three locations. Our main location is at 5920 Gateway Industrial Dr, Belleville, IL 62223. We can be reached at (866) 225-7623, or you can email us at info@cooling-concepts.com.

