

28 Foot Refrigerated Trailer Multi-Temp

Cooling Concepts Trailer Leasing provides only the highest-quality equipment on the market today. All units come equipped with satellite tracking and breakdown assistance is available 24-hours a day.

(800) 225-7623

www.Cooling-Concepts.com

The future of the refrigerated trailer leasing industry is here.

Cooling Concepts 28-foot multi-temp trailer is designed for customers who need a trailer for city/ local deliveries. What makes this trailer so great is that it can be divided up into three different temperature zones, allowing customers to haul various products. The first zone is frozen products. The second zone is for products that need to be kept fresh, and the third zone is for dry products. These separate zones temperatures can all be changed as needed. The 28-foot multi-temp can even be used both as a single temp and dual temp. It is fully customizable for our customers' needs.

Cooling Concepts Standard:

We at Cooling Concepts are here to help the client and change the standard in refrigerated trailer leasing. We do that by offering our client these features for no extra cost.

Solar Panels

Extends the battery life to reduce downtime

GPS & Temperature Reporting

Remotely monitor temperature, location, and driver behavior

Air ride Suspension

Extremely Smooth Ride to protect Cargo

Low rolling Resistance tires

Reduces harmful emissions and Fuel usage

Hybrid refrigeration units.

Ability to operate on both diesel and electric

Fuel Efficiency

Our Smartway® trailers exceed California Air Resource Board (CARB) regulations, saving our fleet partners fuel and money while protecting the environment.

CCL Cloud

Featuring on-demand accounting, storing and tracking of important documentation, the CCL Cloud portal saves time and money and is a value-added standard feature on all Cooling Concepts refrigerated trailer leases.

Cool Connect Satellite Tracking

Satellite tracking allows you to pinpoint truck locations, protect your assets, and determine exactly when to expect delivery. In short, it takes the guesswork out of refrigeration transportation.

Maintenance And Roadside Assistance

In the case of needing roadside assistance, Cooling Concepts is on-call 24/7. Additionally, our preventative maintenance package is available on trailers and refrigeration units, reduces breakdowns and costs.

Trailer Options

Along with the Cooling Concept Standard, there is a list options to help further customize our trailers to our client’s specific needs. These options are:

- Moveable Bulkheads
- Etrack
- Interior lighting
- Walk ramps
- Side mount Ramps
- Lift Gates
- Pop-up air chutes (center)
- Trailer Undertray System
- Puncture Guard tires

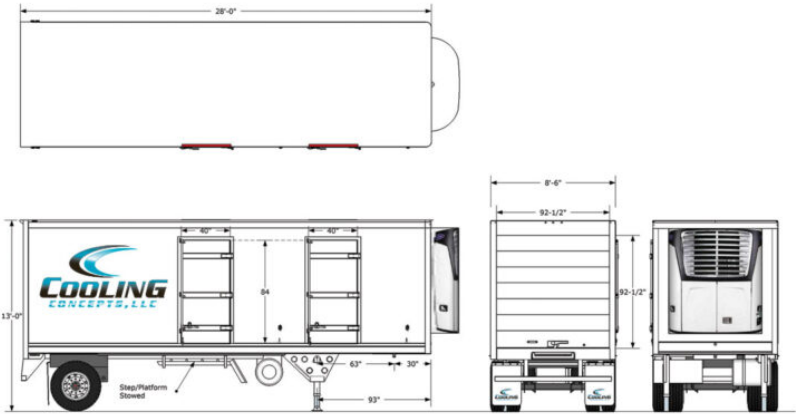

Trailer Dimensions & Spec Sheet

See how the Cooling Concepts 53 Foot Refrigerated Trailer fits in with your fleet needs.

36 FOOT REFRIGERATED TRAILER MEASUREMENTS & SPECIFICATIONS

Overall Length	27'
Overall Width	102"
Overall Height	13'6"
Coupler Height	47"
Kingpin Setting	30"
Dock Height	N/A
Inside Width	N/A
Inside Height	N/A
Door Opening	30" height x 90" width
Slide Doors	2 slide doors 84" height x 40' width
Cubic Capacity	N/A
Weight	16,200 lbs. +/-3%
Suspension	Saf Holland SP9000 series Duralite Spring Suspension

Axles	P-Spindle type
Tires	295/75R 22.5 premium radial tires
Refrigeration Unit	THERMO KING Spectrum or Carrier Genesis
Full Tank	50 gallon aluminum fuel tank

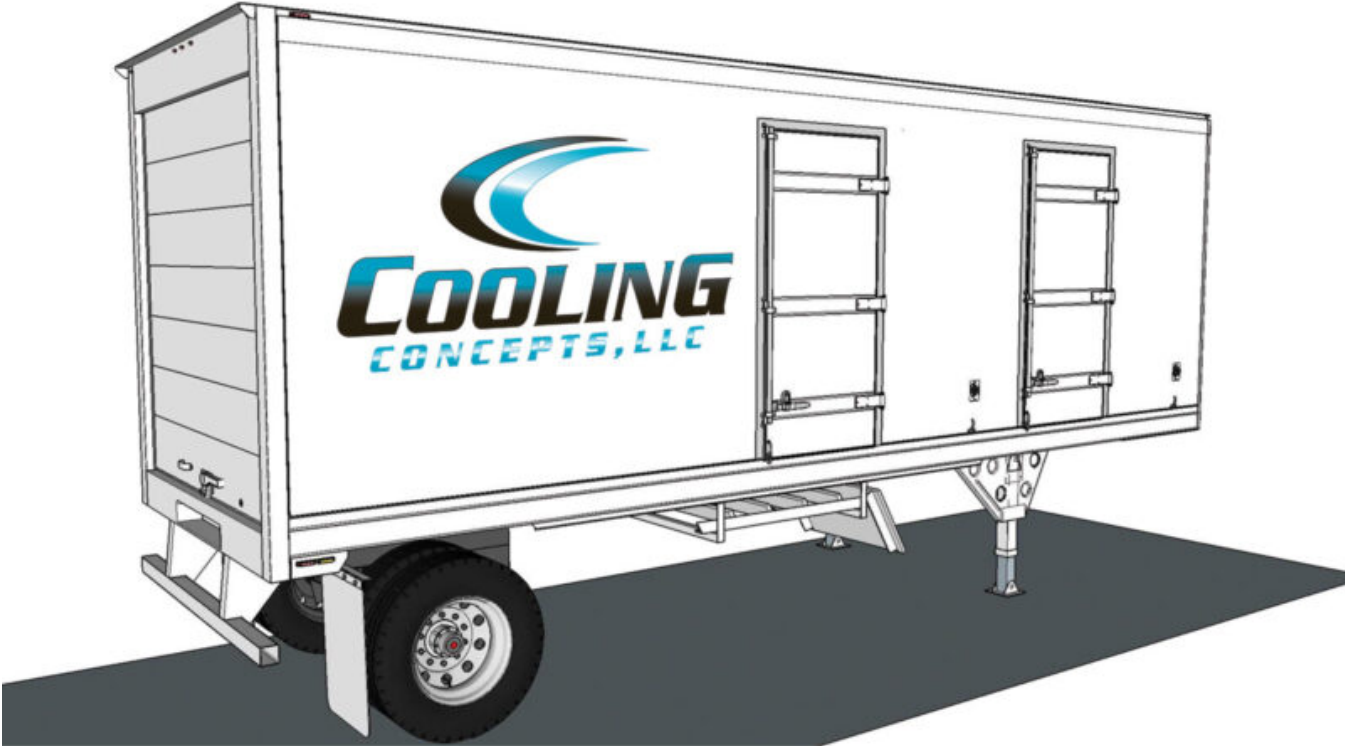

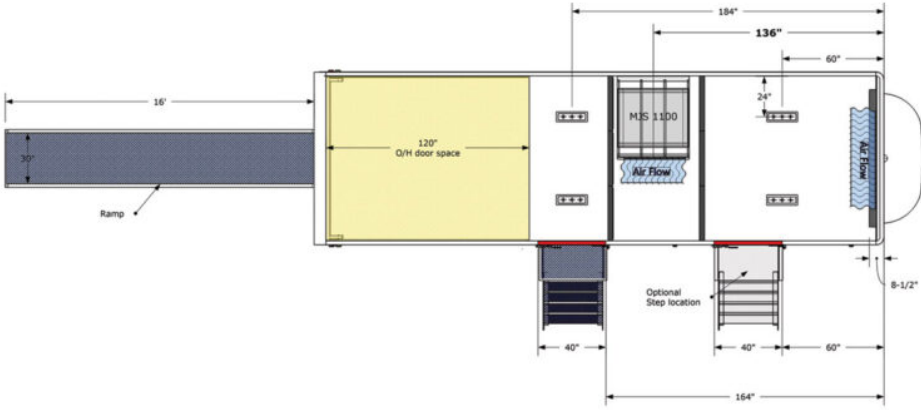
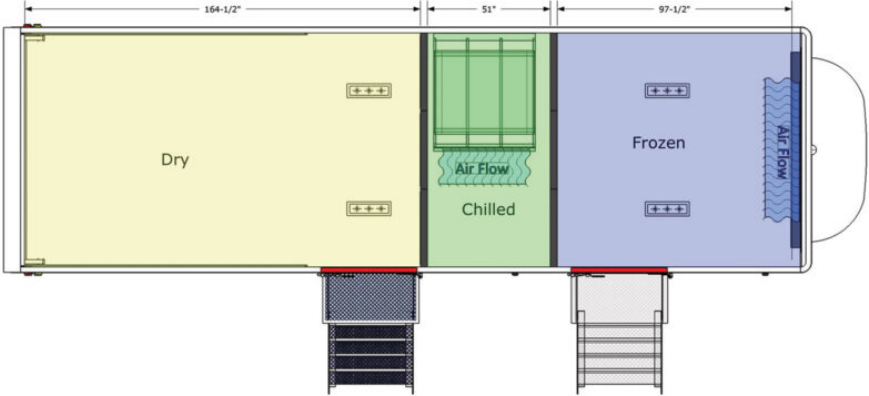

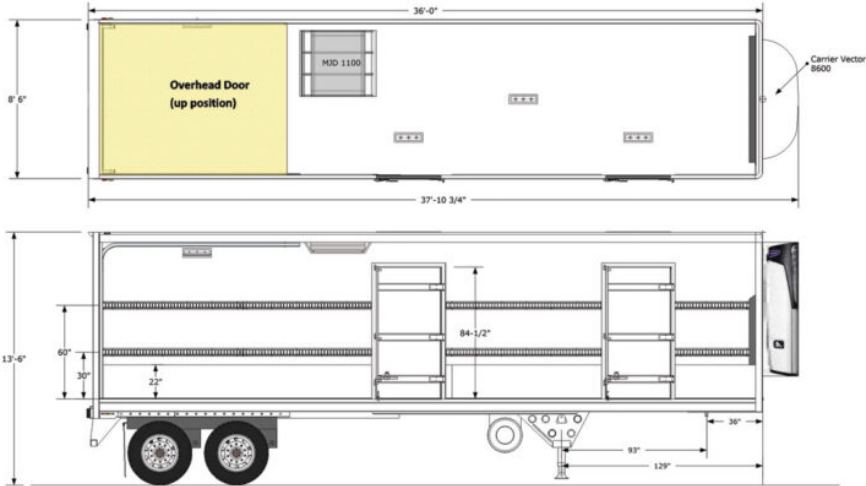
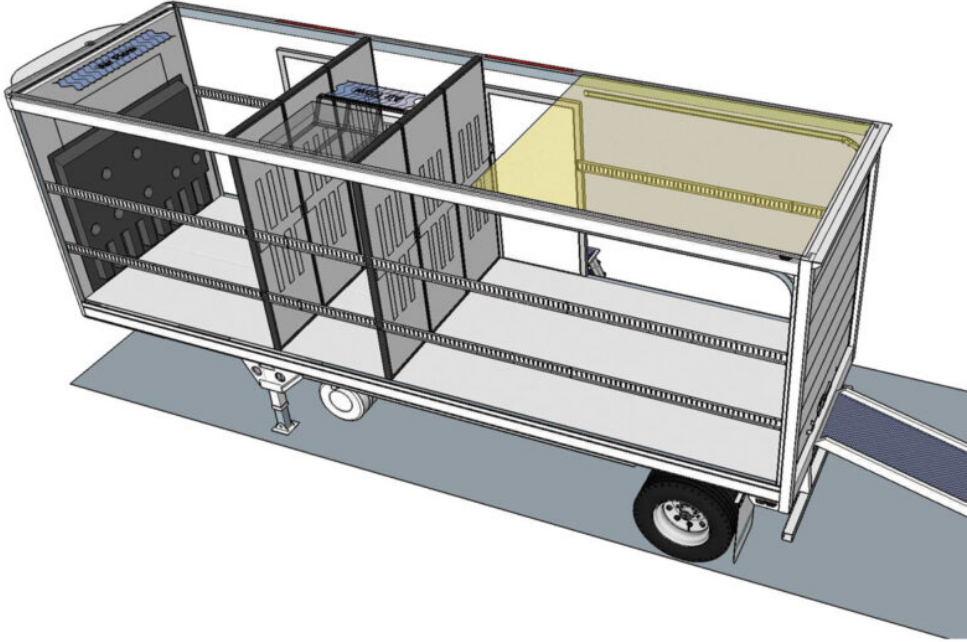

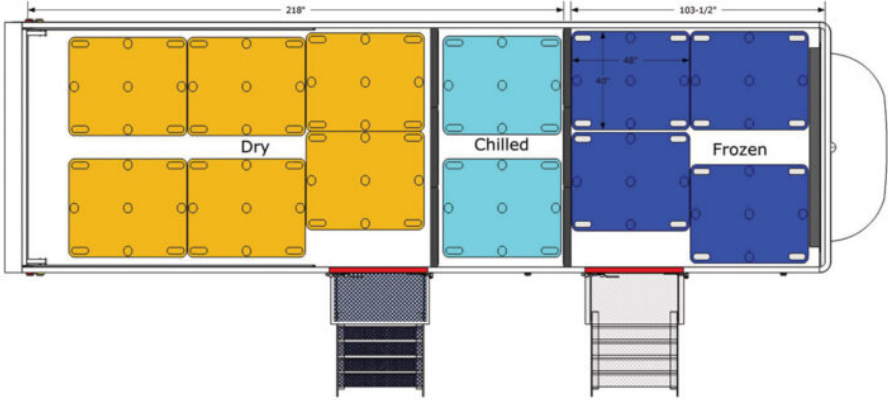
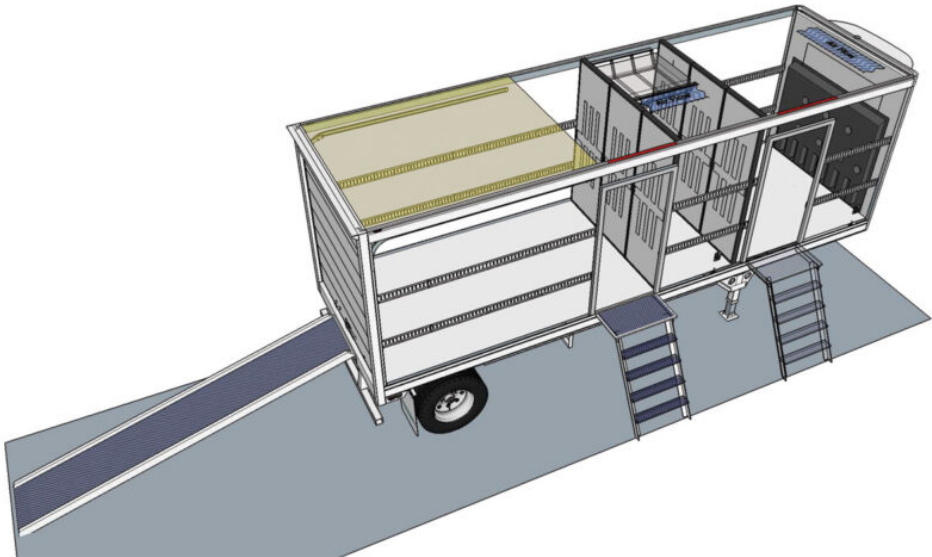

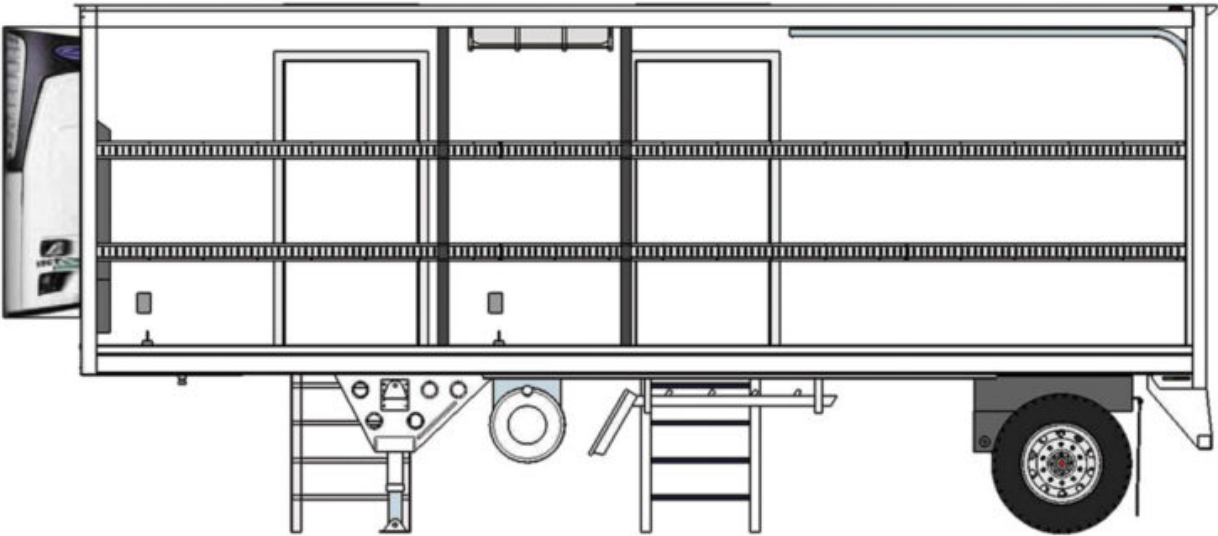
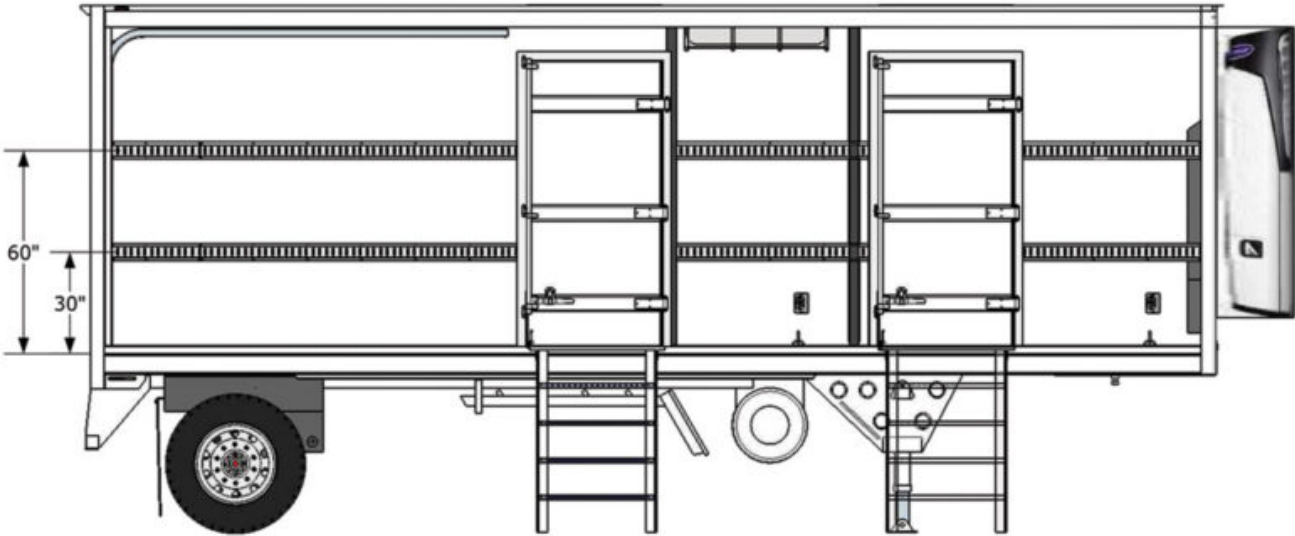

CONTACT US

If you need further assistance or have any question be sure to contact us at one of our three locations. Our main location is at 5920 Gateway Industrial Dr, Belleville, IL 62223. We can be reached at (866) 225-7623, or you can email us at info@cooling-concepts.com.

